

EM SERIES
DM SERIES
DM422C
DM556
DM870
DM1182
DM2282
DM683
DM805-AI
M SERIES

# EM Series Digital Stepper Drives

*Sensorless stall detection and Super-low motor noise*



## Innovative Technologies

- Sensorless Stall Detection
- Super-low Motor Noise
- User Password Protection
- Anti-Resonance Technology
- Low-speed Ripple Smoothing
- Multi-stepping Technology
- Soft Start Technology
- Self-test and Auto-setup

## Specifications

Type	Model	Voltage	RMS Cur.	Matching Motors
DC Input	EM402	20-40 VDC	0.07-1.6A	NEMA8 to 23
	EM503	20-50 VDC	0.21-3.0A	NEMA14 to 23
	EM705	20-78 VDC	0.35-5.7A	NEMA17 to 34
	EM806	24-80 VDC	0.35-6.0A	NEMA23 to 34
AC Input	EM1206H*	80-150 VAC	0.35-6.0A	NEMA34 to 42
	EM2306H*	80-230 VAC	0.35-6.0A	NEMA34 to 51

● Over voltage, over current, short-circuit protections and fault out.  
 \*Available time: to be determined.

# Innovative Technologies

EM SERIES
DM SERIES
DM422C
DM556
DM487D
DM1182
DM2282
3DM683
DM805-AI
M-SERIES

## 1 Sensorless Stall Detection

By detecting motor voltage, current, and back-emf signal, EM series drives can detect loss-of-synchronization of stepper motors without encoders. The sensorless stall detection eliminates cost of feedback devices and time of cable connection.

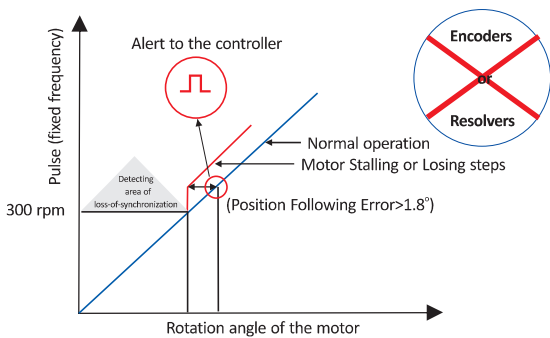

## 2 Super-low Motor Noise

Precision current control technology and multi-stepping technology can reduce about 70% motor noise, making the EM series to be an ideal solution for the applications require low motor noise.

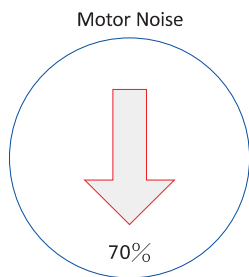

## 4 Anti-Resonance at Mid-range

Most stepper systems resonate at mid-range speed between 10 to 18 rps. EM stepper drives can calculate natural frequency of the stepper system and apply damping in control algorithm for anti-resonance, Providing optimizing torque and nulling mid-range instability.

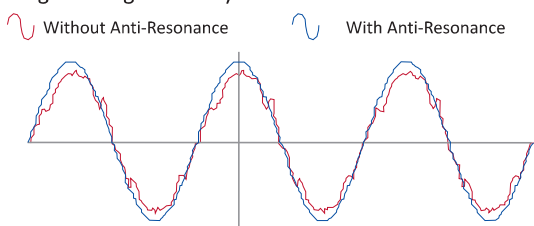

## 3 Low-speed Ripple Smoothing

Electronic damping for 3 major resonance frequencies for stepper motors at low speed range, eliminating undesirable motor speed oscillation and delivering unique level of smoothness.

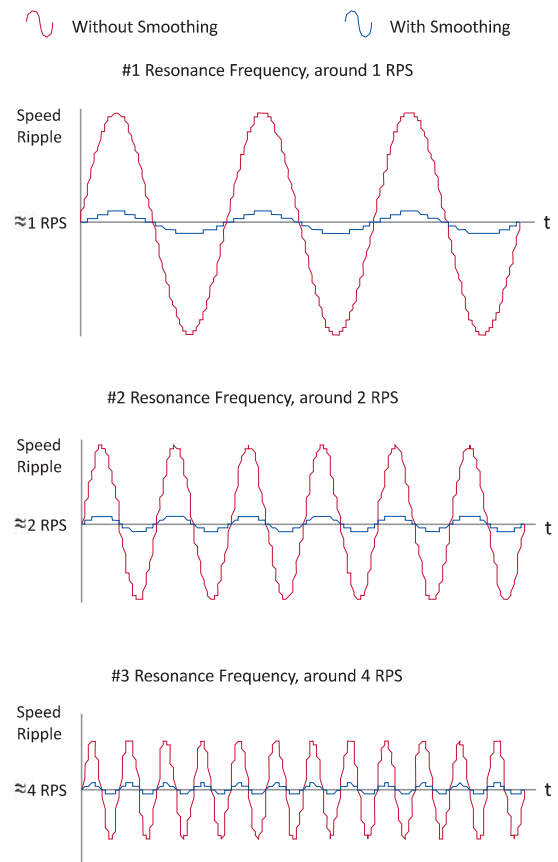

## 5 Multi-stepping Technology

Multi-stepping allows a low resolution input to produce a higher microstep output for smoother system performance. This function can improve smoothness of the stepper systems without upgrading your motion controllers.

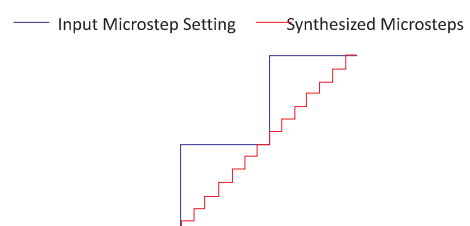

- EM SERIES
- DM SERIES
- DM422C
- DM556
- DM870
- DM1182
- DM2282
- DM683
- DM805-AI
- M SERIES

# Innovative Technologies

## 6 Command Signal Smoothing

Command signal smoothing can soften the effect of sudden changes in velocity and direction, thus delivering smoother performance and improving system lifetime.

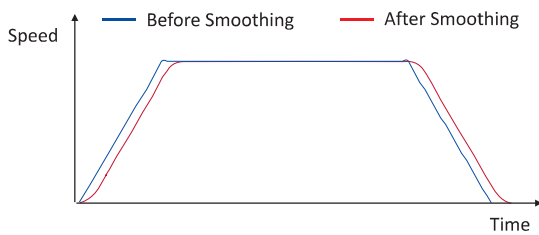

## 7 Soft Start Technology

On power up of a stepper motor, soft start technology allows a stepper motor gradually applying the shaft torque to the load and avoid "starting shock" to the machine. This function is implemented through software, so no additional hardware needed.

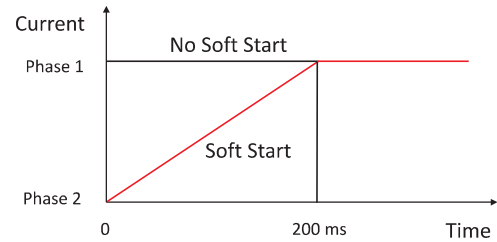

## 8 Lower Heating Technology

Due to DSP precision current control algorithm, motor heat is 10–20 °C lower compare to a traditional stepper drive. Longer motor lifetime can be achieved, reducing maintenance cost. Drive heat is also 20% lower, offering higher drive stability and energy efficiency.

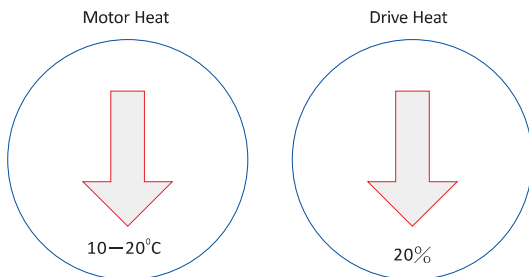

## 9 Torque Improvement

Torque improvement increases torque up to 30% at high speed, therefore they can drive a normal stepper motor to 3000 RPM or even higher, and significantly increase production efficiency.

Torque at High Speed

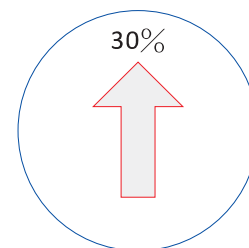

## 10 Self-test and Auto-configuration

Motor-self-test and parameter-auto-configuration technology offers optimum performance for different motors. It is easier for users to configure different axes or build different machines.



Turn SW4 2 times switch in 1 second .

## 11 User Password Protection

User password protection allows you to prevent others from copying your stepper drive configuration.





- EM SERIES
- DM SERIES
- DM422C
- DM556
- DM870
- DM1182
- DM2282
- 3DM683
- DM805-AI
- M SERIES

## Features

- **Sensorless stall detection** eliminates cost of feedback devices and time of cable connection
- **Super-low motor noise** offers excellent quietness
- **User password protection** prevents others from copying your drive configurations
- **Anti-Resonance** optimizes torque and nulls mid-range instability
- **Self-test and Auto-configuration** technology offers optimum performance for different motors
- **Multi-stepping** allows a low resolution input to produce a higher microstep output for smoother system performance
- Built-in controller for simple test, easier to test the drive or system
- Options to set output current and microstep resolutions via DIP switch or software
- Command input of step&direction and CW/CCW pulse\*
- Over-current, over-voltage, short-circuit protections besides sensorless stall detection
- **Fault out** prevents damages to your machines or the materials

## Introduction

By implementing the latest motion control technologies, Leadshine's EM series DSP-based stepper drives deliver excellent performance not available before. Unique features of sensorless stall detection, extra smoothness and excellent high speed performance make EM stepper drives deliver servo-like performance at the cost of stepper drives. They are capable of delivering high performance without damages to your machines or the materials. Leadshine EM series stepper drives are able to drive 2-phase stepper motors from NEMA8 to NEMA51.

## Part Number

<b>3</b>	—	<b>EM</b>	—	<b>80</b>	—	<b>6</b>	—	<b>H</b>
<b>Phase</b>		<b>Series</b>		<b>Max Input</b>		<b>Max RMS Current</b>		<b>Power Input Type</b>
Blank: 2-phase		EM: EM series		40: 40 V		2: 1.5 A		Blank: DC
3: 3-phase				80: 80 V		6: 6.0 A		H: DC and AC
				...		...		

## Electrical Specifications

Parameters	Input Voltage (VDC)			RMS Current (A)					
	Min	Typical	Max	Min	Typical	Max			
Model									
EM402	+20	+24	+40	0.07	-	2.0			
EM503	+20	+24	+50	0.21	-	3.2			
EM705	+20	+48	+70	0.35	-	5.7			
EM806	+24	+68	+80	0.35	-	6.0			
EM1206H	80VAC/112VDC	115VAC/163VDC	150VAC/212VDC	0.35	-	6.0			
EM2306H	80VAC/112VDC	220VAC/311VDC	240VAC/339VDC	0.35	-	6.0			
Parameters	Pulse Input Frequency (kHz)			Logic Signal Current (mA)			Isolation Resistance (MΩ)		
Model	Min	Typical	Max	Min	Typical	Max	Min	Typical	Max
EM Series	0	-	500	7	10	16	500	-	-

\* The EM402 and E806 only support step&direction command.



### Applications

Leadshine EM stepper drives are suitable for driving a wide range of stepper motors, from NEMA frame size 8 to 51. Typical applications include CNC routers, laser cutters, laser markers, medical equipments, X-Y tables, measurement equipments, etc.

### Pin Assignment

There are two connector types for an EM stepper drive. Connector type P1 (See figure below.) is for control signal connections, and connector type P2 is for power and motor connections. The RS232 communication port is for parameter configurations via computer. See brief descriptions for these connectors and interface below.

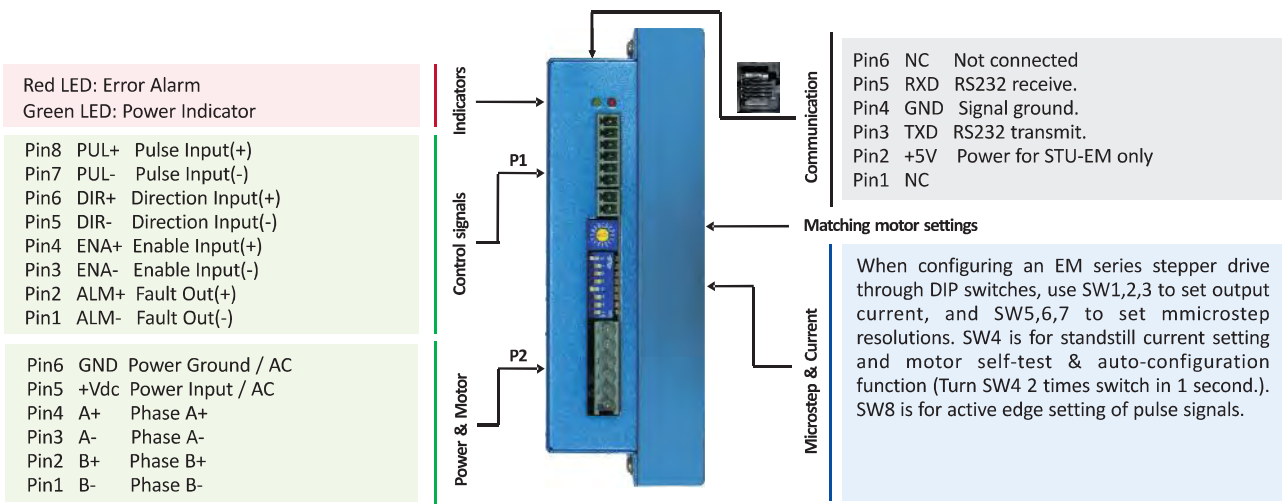

#### Tips:

- Users are suggested to use motor **self-test and auto-configuration** function when powering up the system (with the motor) for the first time, or replacing a new motor.
- To operate at current and microstep settings configured by software or STU, DIP switch must set to default mode.
- Only software **ProTuner** can be used to configure anti-resonance parameter settings.
- How many times the RED light blinks on in a periodic time indicates what protection has been activated. See manuals for detail.

### PC Based and Handheld Configuration/Tuning Tools

For most of applications, configurations set by self-test and auto-configuration function should be good enough to meet the application requirements. However, a user can also configure the advanced features such as anti-resonance and advanced current loop tuning through software or STU-EM, a simple device specially designed for easy tuning.

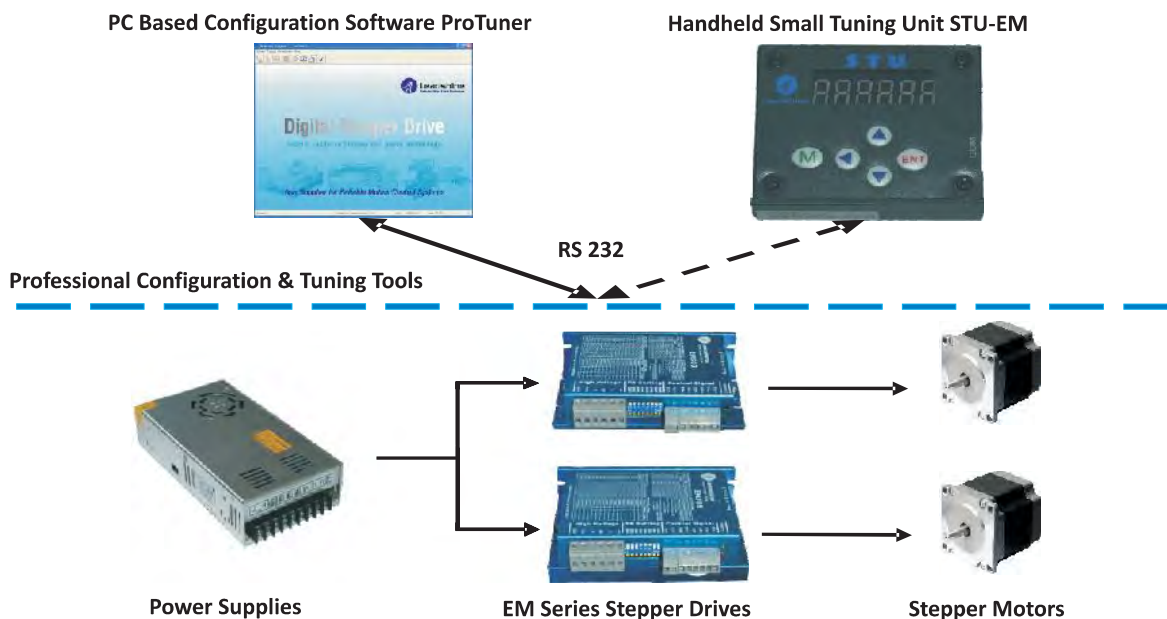



EM SERIES
DM SERIES
DM422C
DM556
DM487D
DM1182
DM2282
3DM683
DM805-AI
M SERIES

### ProTuner (Windows Based Setup Software)

- User password setting
- Upload and Download parameter settings
- PI parameter settings for current loop
- Microstep resolution and output current setting
- Electronic damping coefficient setting
- Anti-resonance parameter settings for 3 resonance areas
- DIR and ALM logic level setting
- Enable and disable sensorless stall detection, ENA reset function and command signal smoothing
- Parameter settings for self motion test
- Save, open, upload and download a configuration file
- Read the latest 10 failure events and clear these events

\* 1 PC RS232 interface is necessary.

\*\* Leadshine offers special cable for communication between ProTuner and the drive.

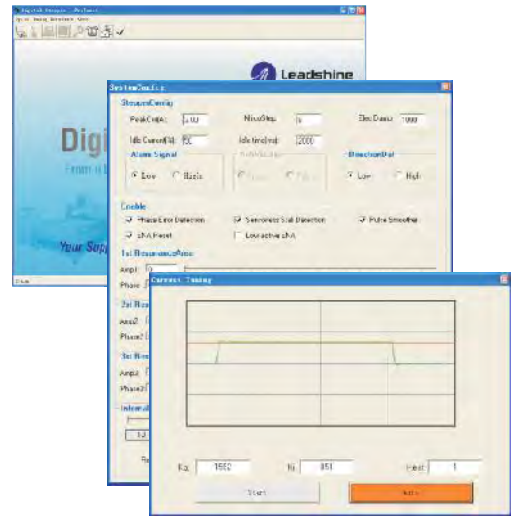

### STU-EM (Handheld Configuration and Tuning Unit)

- Upload and Download parameter settings
- PI parameter settings for current loop
- Microstep resolution and output current setting
- Electronic damping coefficient setting
- DIR and ALM logic level setting
- Enable and disable sensorless stall detection, ENA reset function and command signal smoothing
- Parameter settings for self motion test
- Upload and download a configuration file

\* Leadshine offers special cable for communication between the STU-EM and the drive.



### Typical Connections

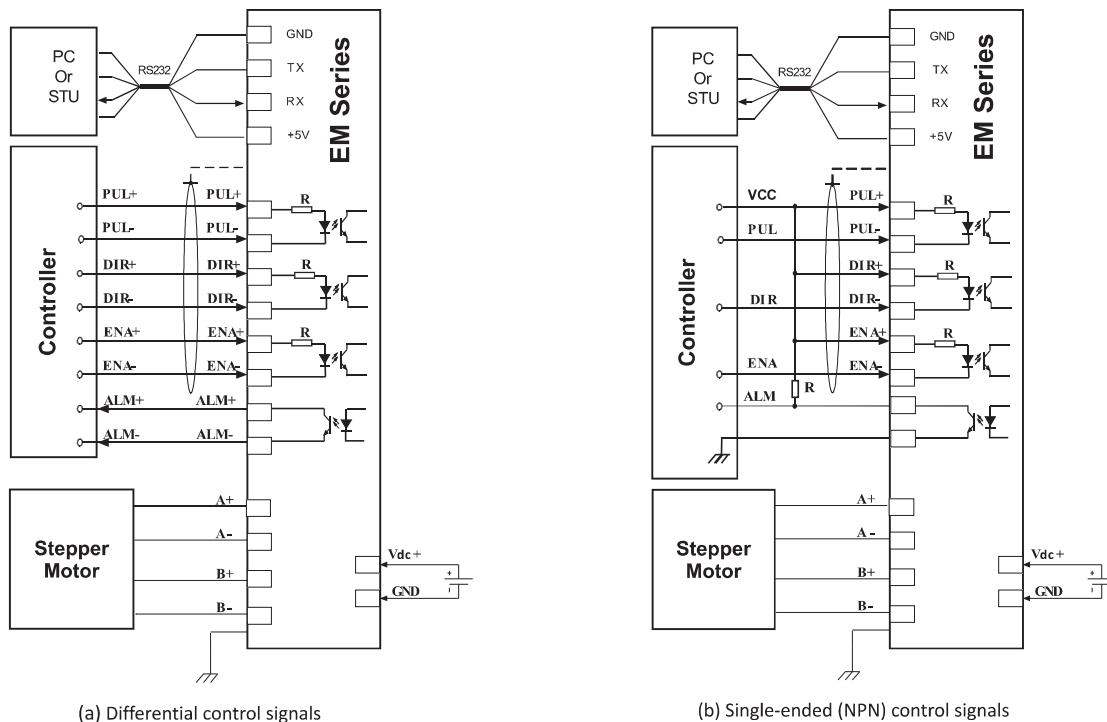

## Speed-Torque Curves of Pre-set Matching Motors\*

EM SERIES

DM SERIES

DM422C

DM556

DM870

DM1182

DM2282

DM683

DM805-AI

M SERIES

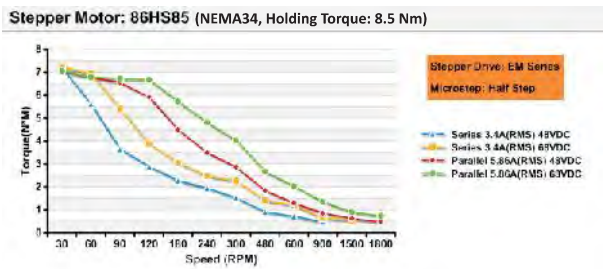
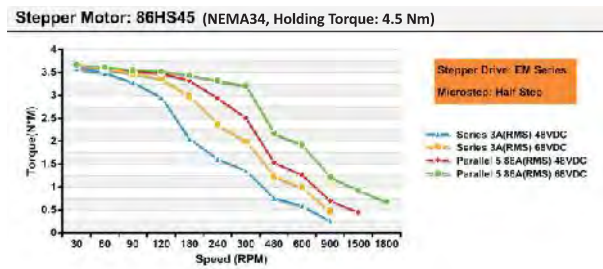
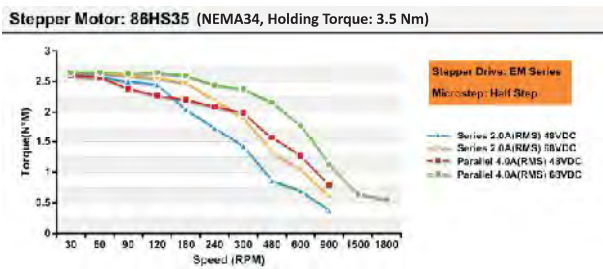
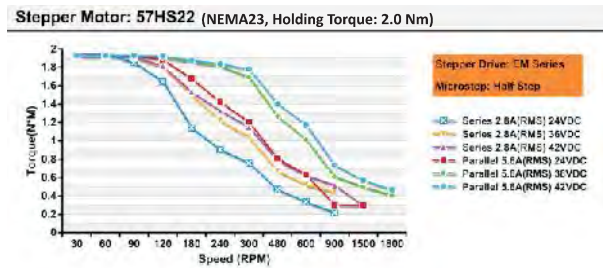
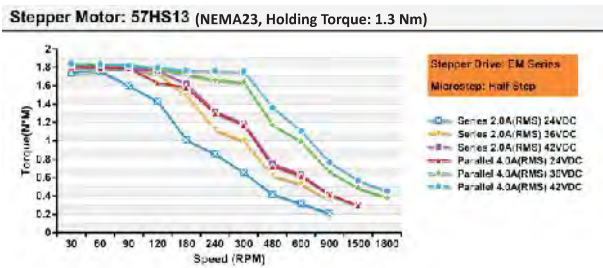
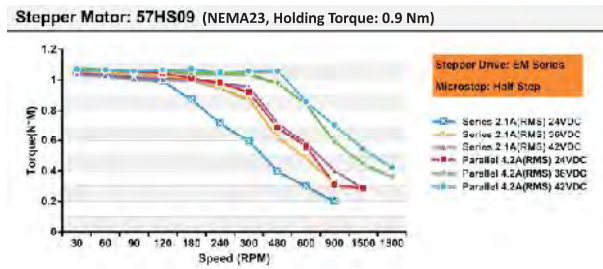
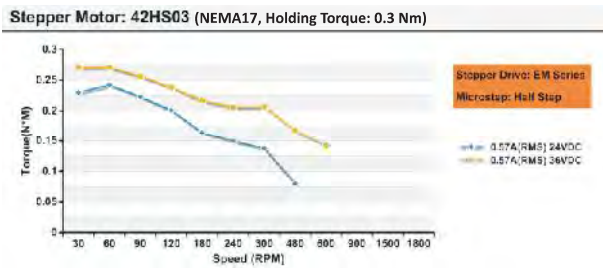
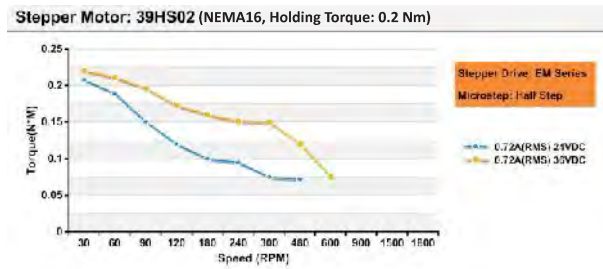
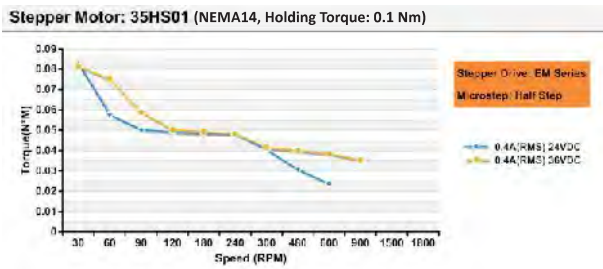

\* Other curves will be released soon.

**Mechanical Specifications (Unit: mm 1 inch=25.4mm)**

Units: mm 1 inch=25.4mm

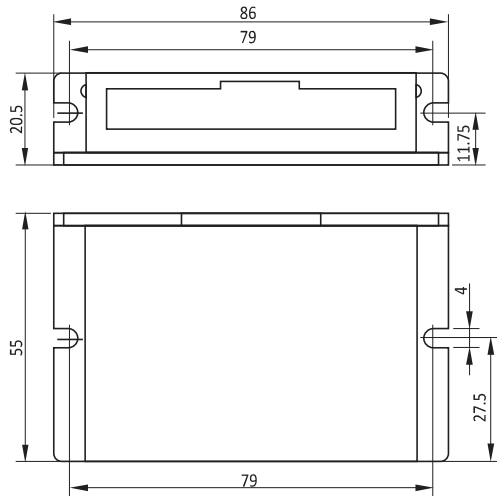

(a) Mechanical specifications of the EM402

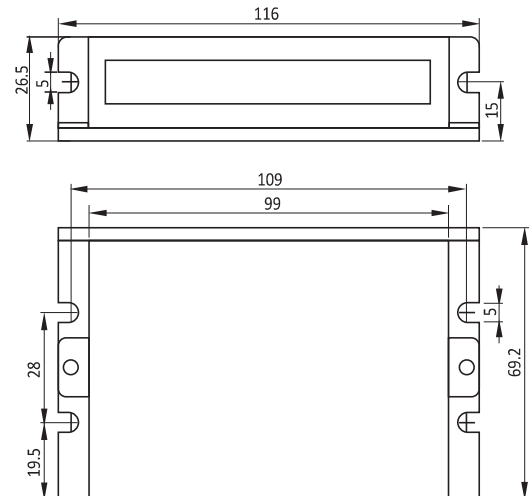

(b) Mechanical specifications of the EM503

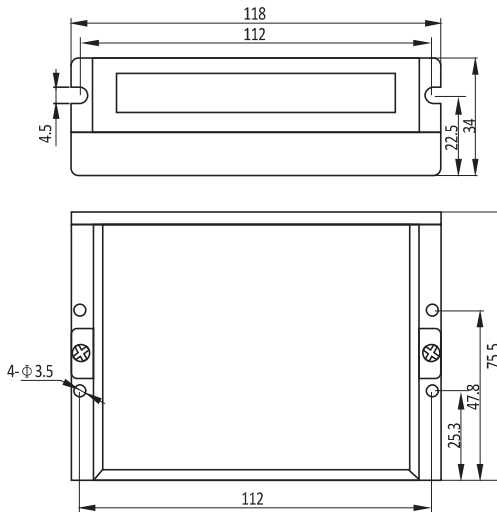

(c) Mechanical specifications of the EM705

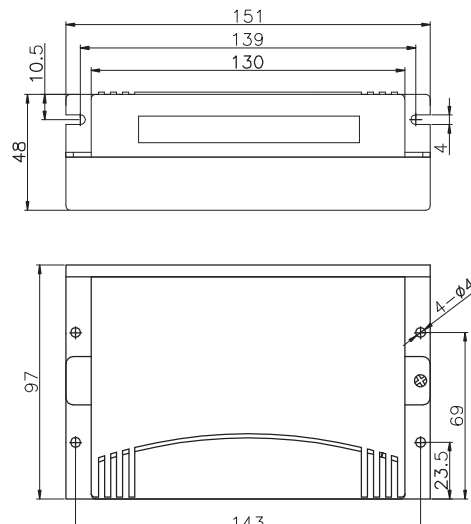

(d) Mechanical specifications of the EM806

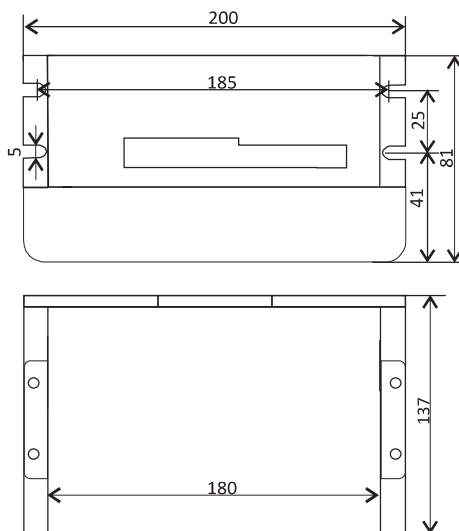

(e) Mechanical specifications of the EM1206H and EM2306H

EM SERIES
DM SERIES
DM422C
DM556
DM487D
DM1182
DM2282
3DM683
DM805-AI
M SERIES



# EM402 2-phase Digital Stepper Drive

## 20-40V, 0.07-2A, Sensorless Stall Detection, Pre-Matching Motor



- **Sensorless stall detection** eliminates cost of feedback devices and time of cable connection
- **Super-low** motor noise offers excellent quietness
- **User password protection** prevents others from copying your drive configurations
- **Anti-Resonance** optimizes torque and nulls mid-range instability
- Self-test and Auto-configuration technology offers optimum performance for different motors
- Multi-stepping allows a low resolution input to produce a higher microstep output for smoother system performance
- Options to set output current and microstep resolutions via DIP switch or software
- Command input of PUL/DIR, Microstep from 1 to 512
- Automatic idle-current reduction and reduction rate is software configurable
- Over-current, over-voltage, short-circuit protections besides sensorless stall detection
- Fault out prevents damages to your machines or the materials

### Descriptions

By implementing the latest motion control technologies, Leadshine's EM series DSP-based stepper drives deliver excellent performance not available before. Unique features of sensorless stall detection, extra smoothness and excellent high speed performance make EM stepper drives deliver servo-like performance at the cost of stepper drives. They are capable of delivering high performance without damages to your machines or the materials. Leadshine EM series stepper drives are able to drive 2-phase or 3-phase stepper motors from NEMA8 to NEMA23

### Applications

EM402 stepper drives are suitable for driving a wide range of stepper motors, from NEMA frame size 8 to 23. Typical applications include CNC routers, laser cutters, laser markers, medical equipments, X-Y tables, measurement equipments, etc.

## Specifications

### Electrical Specifications

Parameter	Min	Typical	Max	Unit
Input Voltage	20	24	40	VDC
Pulse Input Frequency	0	-	50	kHz
Logic Signal Current	7	10	16	mA
Isolation Resistance	500	-	-	MΩ

### Operating Environment

<b>Cooling</b>	Natural Cooling or Forced cooling	
<b>Operating Environment</b>	Environment	Avoid dust, oil fog and corrosive gases
	Storage Temperature	-20°C – 65°C (-4°F – 149°F)
	Ambient Temperature	0°C – 50°C (32°F – 122°F)
	Humidity	40%RH – 90%RH
	Operating Temperature (Heat Sink)	70°C (158°F) Max
	Vibration	10-55Hz, 0.15mm/s
<b>Storage Temperature</b>	-20°C – 65°C (-4°F – 149°F)	
<b>Weight</b>	107 g (3.77 oz)	

## Mechanical Specifications

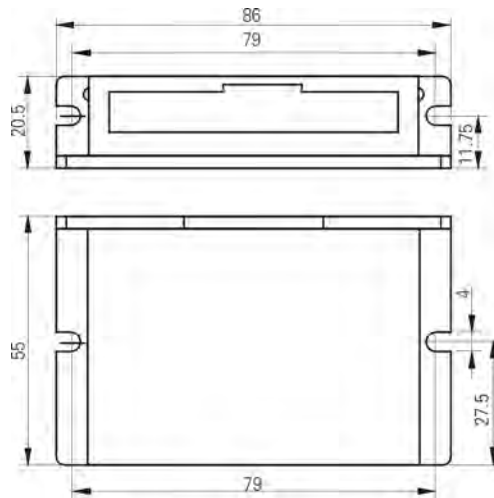

## Protection Indications

The green indicator turns on when power-up. When drive protection is activated, the red LED blinks periodicity to indicate the error type

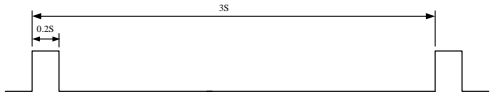
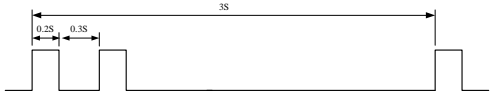
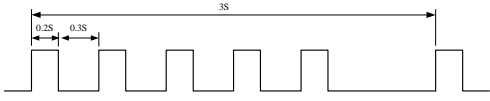
Priority	Time(s) of Blink	Sequence wave of RED LED	Description
1st	1		Over-current protection
2nd	2		Over-voltage protection
3rd	5		Motor Stall Protection

## Connectors and Pin Assignment

The EM402 has two connectors, connector for control signals connections, and connector for power and motor connections.

Control Signal Connector			
Pin	Name	I/O	Description
1	PUL+	I	<u>Pulse signal</u> : This input represents pulse signal, each rising or falling edge active (software configurable, see EM drives software operational manual for more detail); 4-5V when PUL-HIGH, 0-0.5V when PUL-LOW.
2	PUL-	I	For reliable response, pulse width should be longer than 10μs. Series connect resistors for current-limiting when +12V or +24V used. The same as DIR and ENA signal.
3	DIR+	I	<u>Direction Signal</u> : This signal has low/high voltage levels, representing two directions of motor rotation. For reliable motion response, DIR signal should be ahead of PUL signal by 5μs at least. 4-5V when DIR-HIGH, 0-0.5V when DIR-LOW. Please note that rotation direction is also related to motor-driver wiring match.
4	DIR-	I	Exchanging the connection of two wires for a coil to the driver will reverse motion direction. The direction polarity is software configurable,. See EM drives software operational manual for more detail.
5	ENA+	I	<u>Enable signal</u> : This signal is used for enabling/disabling the driver. In default, high level (NPN control signal) for enabling the driver and low level for disabling the driver. Usually left <b>UNCONNECTED (ENABLED)</b> .
6	ENA-	I	Please note that PNP and Differential control signals are on the contrary, namely Low level for enabling. The active level of ENA signal is software configurable. See EM drive's software manual for more detail.
7	FLT+	O	<u>Fault Signal</u> : OC output signal activated when over-voltage, over current and stall-error protection. This port can sink or source 20mA current at 24V. In default, the resistance between FLT+ and FLT- is low impedance in normal operation and become high impedance when EM402 goes into error. The active level of fault signal can be programmable. See EM drives software operational manual for more detail.
8	FLT-	O	

Power and Motor Connector			
Pin	Name	I/O	Description
1	A+	O	Motor Phase A+
2	A-	O	Motor Phase A-
3	B+	O	Motor Phase B+
4	B-	O	Motor Phase B-
5	+Vdc	I	Power Supply Input (Positive), 20-36VDC recommended, leaving rooms for voltage fluctuation and back-EMF.
6	GND	GND	Power Ground (Negative)

## RS232 Communication Port

It is used to configure the peak current, microstep, active level, current loop parameters and anti-resonance parameters. See EM driver's software operational manual for more information.

RS232 Communication Port			
Pin	Name	I/O	Description
1	NC	-	Not connected.
2	+5V	O	+5V power only for STU (Simple Tuning Unit).
3	TxD	O	RS232 transmit.
4	GND	GND	Ground.
5	RxD	I	RS232 receive.
6	NC	-	Not connected.

## DIP Switch Settings

### Dynamic Current

Peak	RMS	SW1	SW2
<b>Default</b>	<b>Default</b>	on	on
0.7A	0.5A	of	on
1.5A	1.1A	on	off
2.2A	1.6A	off	off

**Note:** Due to motor inductance, the actual current in the coil may be smaller than the dynamic current setting, particularly under high speed condition.

### Idle-Current

SW3 determines whether the idle current is reduced automatic or remains the same as the dynamic current setting.

	ON	OFF
SW3	The motor idle current reduces automatically when there is no pulse applied to EM402.	The motor idle current is the same as the dynamic current when there is no pulse applied to EM402.

### Auto-Configuration

Switch SW3 two times in two seconds to auto-configure the drive's current loop parameter. That is, OFF-ON-OFF or ON-OFF-ON. During Auto-configuration, motor parameters are identified and the EM drive's current loop parameters are calculated automatically. The motor shaft will vibrate a little during the process of Auto-configuration which takes about 1 to 3 seconds.

### Microstep Resolution

Steps/Revolution	SW4	SW5
Software Configured (Default 200)	on	on
400	off	on
800	on	off
1600	off	off

### Motor Selection and Pre-matching Leadshine Motor

Matching Motor	Connection	SW6	SW7	SW8	Description
35HS01	-	on	on	on	Select pre-matching Leadshine stepper motor. EM402 has been tuned for these motors.
39HS02	-	off	on	on	
42HS03	Parallel	on	off	on	
57HS04	Series	off	off	on	
Custom1	-	on	on	off	Select non-Leadshine motor. EM402 needs tuning either by Auto-configuration or the PC software.
Custom2	-	off	on	off	
Custom3	-	on	off	off	There are up to four custom positions for customer selection.
Custom4	-	off	off	off	

### Speed Torque Curve for Pre-matching Leadshine Motor

Stepper Motor: 35HS01

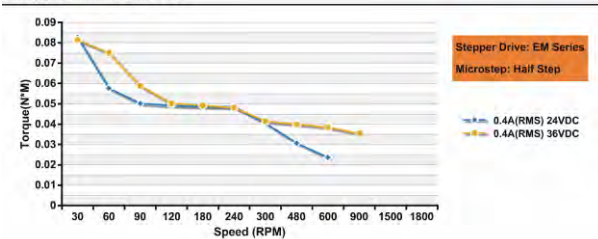

Stepper Motor: 39HS02

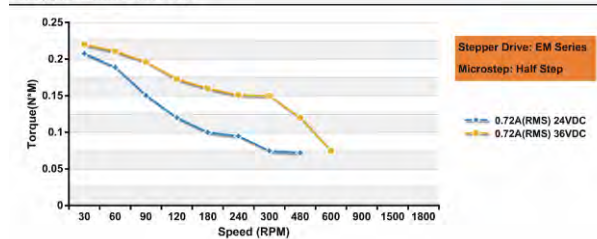

Stepper Motor: 42HS02

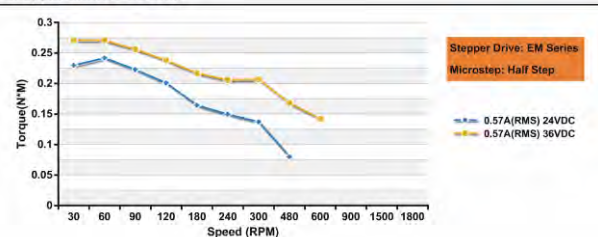

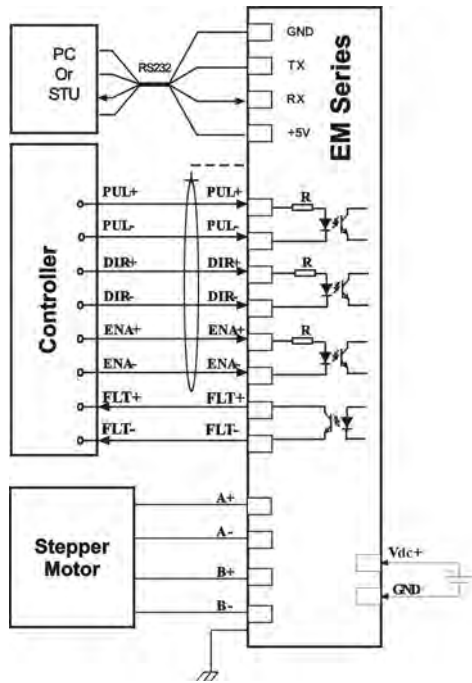
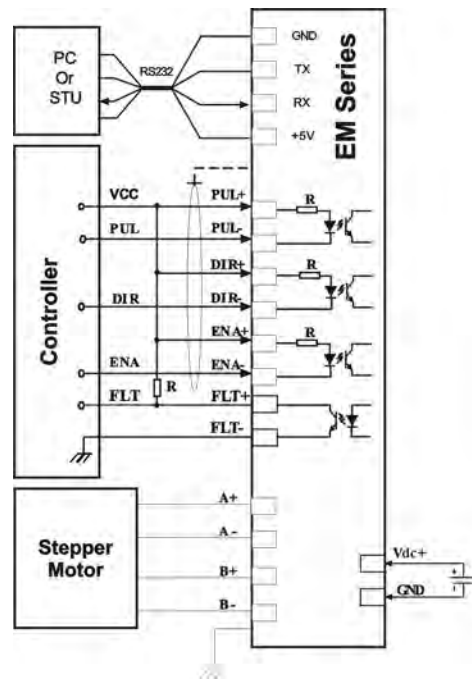

**Typical Connections**
**Differential Control Signal**

**NPN Control Signal**

# EM503 2-phase Digital Stepper Drive

## 20-50V, 0.21-3A, Sensorless Stall Detection, Pre-Matching Motor



- **Sensorless stall detection** eliminates cost of feedback devices and time of cable connection
- **Super-low** motor noise offers excellent quietness
- **User password protection** prevents others from copying your drive configurations
- **Anti-Resonance** optimizes torque and nulls mid-range instability
- Self-test and Auto-configuration technology offers optimum performance for different motors
- Multi-stepping allows a low resolution input to produce a higher microstep output for smoother system performance
- Options to set output current and microstep resolutions via DIP switch or software
- Command input of PUL/DIR or CW/CCW, Microstep from 1 to 512
- Automatic idle-current reduction and reduction rate is software configurable
- Over-current, over-voltage, short-circuit protections besides sensorless stall detection
- Fault out prevents damages to your machines or the materials

### Descriptions

By implementing the latest motion control technologies, Leadshine's EM series DSP-based stepper drives deliver excellent performance not available before. Unique features of sensorless stall detection, extra smoothness and excellent high speed performance make EM stepper drives deliver servo-like performance at the cost of stepper drives. They are capable of delivering high performance without damages to your machines or the materials. Leadshine EM series stepper drives are able to drive 2-phase or 3-phase stepper motors from NEMA8 to NEMA42.

### Applications

EM503 stepper drives are suitable for driving a wide range of 2-phase stepper motors, from NEMA frame size 14 to 23. Typical applications include CNC routers, laser cutters, laser markers, medical equipments, X-Y tables, measurement equipments, etc.

## Specifications

### Electrical Specifications

Parameter	Min	Typical	Max	Unit
Input Voltage	20	36	50	VDC
Pulse Input Frequency	0	-	200	kHz
Logic Signal Current	7	10	16	mA
Isolation Resistance	500	-	-	MΩ

### Operating Environment

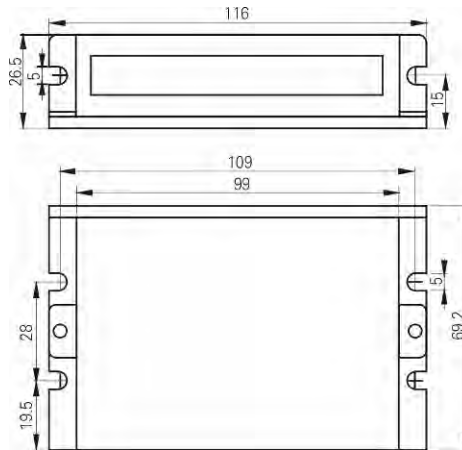

Cooling	Natural Cooling or Forced cooling	
Operating Environment	Environment	Avoid dust, oil fog and corrosive gases
	Storage Temperature	-20°C – 65°C (-4°F – 149°F)
	Ambient Temperature	0°C – 50°C (32°F – 122°F)
	Humidity	40%RH – 90%RH
	Operating Temperature (Heat Sink)	70°C (158°F) Max
	Vibration	10-55Hz, 0.15mm/s
Storage Temperature	-20°C – 65°C (-4°F – 149°F)	
Weight	209 g (7.37 oz)	

## Mechanical Specifications

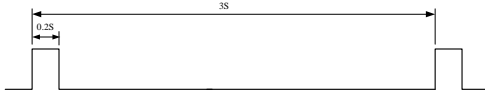

## Protection Indications

The green indicator turns on when power-up. When drive protection is activated, the red LED blinks periodicity to indicate the error type

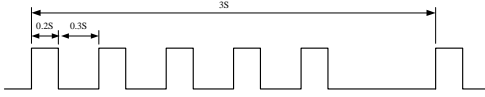
Priority	Time(s) of Blink	Sequence wave of RED LED	Description
1st	1		Over-current protection
2nd	2		Over-voltage protection
3rd	5		Motor Stall Protection

## Connectors and Pin Assignment

The EM503 has two connectors, connector for control signals connections, and connector for power and motor connections.

Control Signal Connector			
Pin	Name	I/O	Description
1	PUL+	I	<u>Pulse signal</u> : In single pulse (pulse/direction) mode, this input represents pulse signal, each rising or falling edge active (software configurable, see EM drives software operational manual for more detail); In double pulse mode (software configurable), this input represents clockwise (CW) pulse, active both at high level and low level. 4-5V when PUL-HIGH, 0-0.5V when PUL-LOW. For reliable response, pulse width should be longer than 10 $\mu$ s. Series connect resistors for current-limiting when +12V or +24V used. The same as DIR and ENA signal.
2	PUL-	I	
3	DIR+	I	<u>Direction Signal</u> : In single-pulse mode, this signal has low/high voltage levels, representing two directions of motor rotation. In double-pulse mode (software configurable), this signal is counter-clock (CCW) pulse, active both at high level and low level. For reliable motion response, DIR signal should be ahead of PUL signal by 5 $\mu$ s at least. 4-5V when DIR-HIGH, 0-0.5V when DIR-LOW. Please note that rotation direction is also related to motor-driver wiring match. Exchanging the connection of two wires for a coil to the driver will reverse motion direction. The direction signal's polarity is software configurable.
4	DIR-	I	
5	ENA+	I	<u>Enable signal</u> : This signal is used for enabling/disabling the driver. In default, high level (NPN control signal) for enabling the driver and low level for disabling the driver. Usually left <b>UNCONNECTED (ENABLED)</b> . Please note that PNP and Differential control signals are on the contrary, namely Low level for enabling. The active level of ENA signal is software configurable.
6	ENA-	I	
7	FLT+	O	<u>Fault Signal</u> : OC output signal, active when one of the following protection is activated: over-voltage, over current, short circuit and stall-error. This port can sink or source 20mA current at 24V. In default, the resistance between FLT+ and FLT- is low impedance in normal operation and become high when EM503 goes into error. The active level of fault signal is software configurable. See EM drives software operational manual for more detail.
8	FLT-	O	

Power and Motor Connector			
Pin	Name	I/O	Description
1	A+	O	Motor Phase A+
2	A-	O	Motor Phase A-
3	B+	O	Motor Phase B+
4	B-	O	Motor Phase B-
5	+Vdc	I	Power Supply Input (Positive), 20-45VDC recommended, leaving rooms for voltage fluctuation and back-EMF.
6	GND	GND	Power Ground (Negative)

### RS232 Communication Port

It is used to configure the peak current, microstep, active level, current loop parameters and anti-resonance parameters. See EM driver's software operational manual for more information.

RS232 Communication Port			
Pin	Name	I/O	Description
1	NC	-	Not connected.
2	+5V	O	+5V power only for STU (Simple Tuning Unit).
3	TxD	O	RS232 transmit.
4	GND	GND	Ground.
5	RxD	I	RS232 receive.
6	NC	-	Not connected.

### DIP Switch Settings

#### Dynamic Current

Peak	RMS	SW1	SW2	SW3
<b>Default</b>	<b>Default</b>	on	on	on
1.46A	1.04A	of	on	on
1.91A	1.36A	on	off	on
2.37A	1.69A	off	off	on
2.84A	2.03A	on	on	off
3.31A	2.36A	of	on	off
3.76A	2.69A	on	off	off
4.20A	3.00A	off	off	off

**Note:** Due to motor inductance, the actual current in the coil may be smaller than the dynamic current setting, particularly under high speed condition.



### Idle-Current

SW3 determines whether the idle current is reduced automatic or remains the same as the dynamic current setting.

	ON	OFF
SW4	The motor idle current reduces automatically when there is no pulse applied to EM503.	The motor idle current is the same as the dynamic current when there is no pulse applied to EM503.

### Auto-Configuration

Switch SW4 two times in two seconds to auto-configure the drive's current loop parameter. That is, OFF-ON-OFF or ON-OFF-ON. During Auto-configuration, motor parameters are identified and the EM drive's current loop parameters are calculated automatically. The motor shaft will vibrate a little during the process of Auto-configuration which takes about 1 to 3 seconds.

### Microstep Resolution

Steps/Revolution	SW5	SW6	SW7	SW8
Software Configured (Default 200)	on	on	on	on
400	off	on	on	on
800	on	off	on	on
1600	off	off	on	on
3200	on	on	off	on
6400	off	on	off	on
12800	on	off	off	on
25600	off	off	off	on
1000	on	on	on	off
2000	off	on	on	off
4000	on	off	on	off
5000	off	off	on	off
8000	on	on	off	off
10000	off	on	off	off
20000	on	off	off	off
25000	off	off	off	off

### Motor Selection and Pre-matching Leadshine Motor

There is a rotation switch used for the motor selection.

Matching Motor	Connection	Code	Description
39HS02	-	0	Select pre-matching Leadshine stepper motor. EM503 has been tuned for these motors.
42HS03	Parallel	1	
57HS09	Parallel	2	
57HS13	Parallel	3	
57HS22	Parallel -	4	
86HS35	Parallel	5	
42HS03	Serial	6	
57HS04	Serial	7	
57HS09	Serial	8	
86HS13	Serial	9	
86HS22	Serial	A	
86HS35	Serial	B	
Custom1	-	C	Select non-Leadshine motor. EM503 needs tuning either by Auto-configuration or the PC software. There are up to four custom positions for customer selection.
Custom2	-	D	
Custom3	-	E	
Custom4	-	F	

### Speed Torque Curve for Pre-matching Leadshine Motor

Stepper Motor: 39HS02

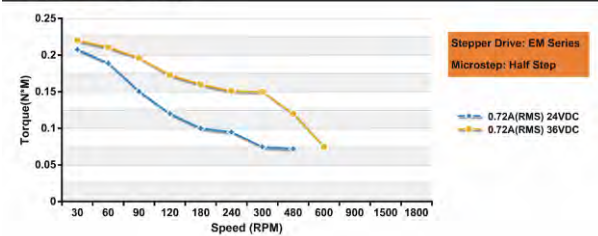

Stepper Motor: 42HS02

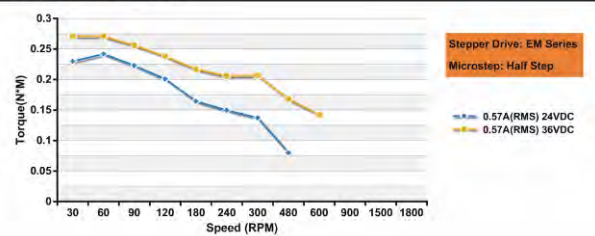

Stepper Motor: 57HS09

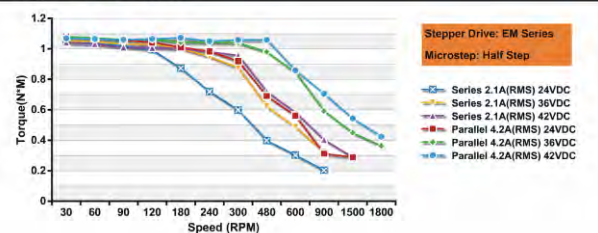

Stepper Motor: 57HS13

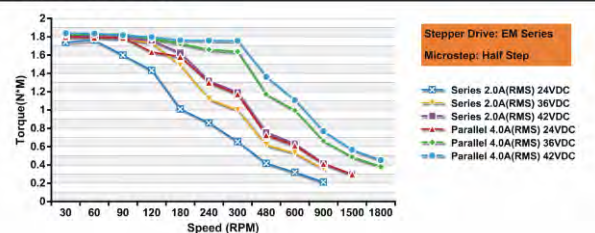

Stepper Motor: 57HS22

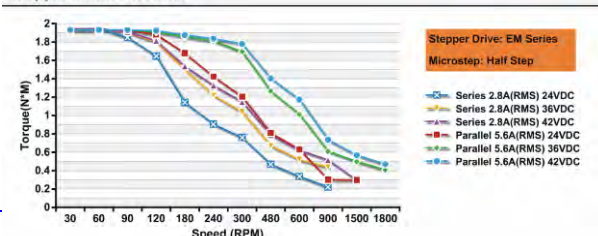

Stepper Motor: 86HS35

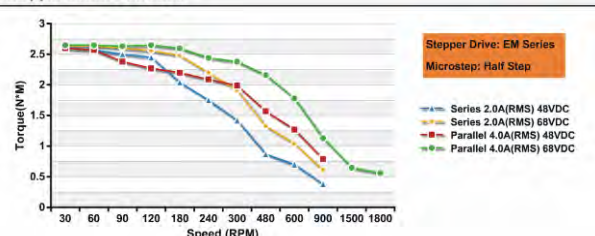

## Typical Connections

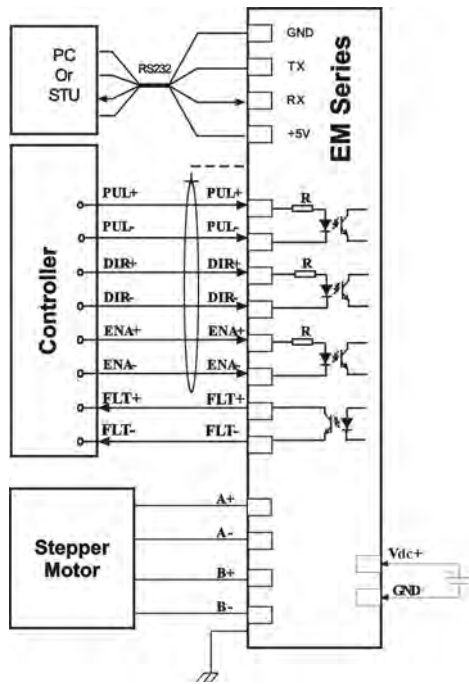
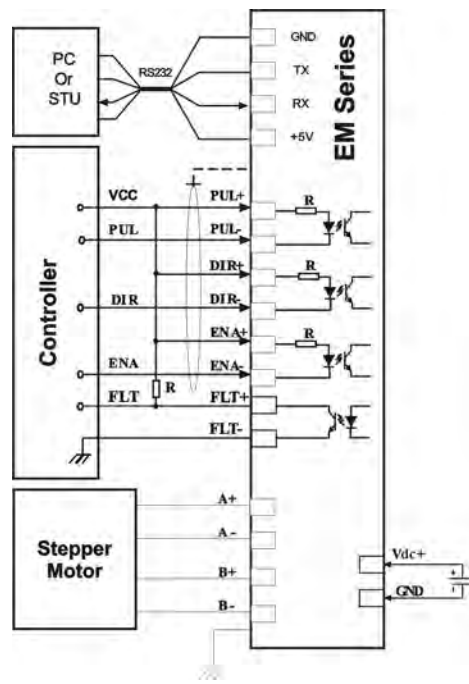
**Differential Control Signal**

**NPN Control Signal**

# EM705 2-phase Digital Stepper Drive

## 20-70V, 0.35-5A, Sensorless Stall Detection, Pre-Matching Motor



- **Sensorless stall detection** eliminates cost of feedback devices and time of cable connection
- **Super-low** motor noise offers excellent quietness
- **User password protection** prevents others from copying your drive configurations
- **Anti-Resonance** optimizes torque and nulls mid-range instability
- Self-test and Auto-configuration technology offers optimum performance for different motors
- Multi-stepping allows a low resolution input to produce a higher microstep output for smoother system performance
- Options to set output current and microstep resolutions via DIP switch or software
- Command input of PUL/DIR or CW/CCW, Microstep from 1 to 512
- Automatic idle-current reduction and reduction rate is software configurable
- Over-current, over-voltage, short-circuit protections besides sensorless stall detection
- Fault out prevents damages to your machines or the materials

### Descriptions

By implementing the latest motion control technologies, Leadshine's EM series DSP-based stepper drives deliver excellent performance not available before. Unique features of sensorless stall detection, extra smoothness and excellent high speed performance make EM stepper drives deliver servo-like performance at the cost of stepper drives. They are capable of delivering high performance without damages to your machines or the materials. Leadshine EM series stepper drives are able to drive 2-phase or 3-phase stepper motors from NEMA8 to NEMA42.

### Applications

EM705 stepper drives are suitable for driving a wide range of 2-phase stepper motors, from NEMA frame size 17 to 34. Typical applications include CNC routers, laser cutters, laser markers, medical equipments, X-Y tables, measurement equipments, etc.

## Specifications

### Electrical Specifications

Parameter	Min	Typical	Max	Unit
Input Voltage	20	48	70	VDC
Pulse Input Frequency	0	-	200	kHz
Logic Signal Current	7	10	16	mA
Isolation Resistance	500	-	-	MΩ

### Operating Environment

<b>Cooling</b>	Natural Cooling or Forced cooling	
<b>Operating Environment</b>	Environment	Avoid dust, oil fog and corrosive gases
	Storage Temperature	-20°C – 65°C (-4°F – 149°F)
	Ambient Temperature	0°C – 50°C (32°F – 122°F)
	Humidity	40%RH – 90%RH
	Operating Temperature (Heat Sink)	70°C (158°F) Max
	Vibration	10-55Hz, 0.15mm/s
<b>Storage Temperature</b>	-20°C – 65°C (-4°F – 149°F)	
<b>Weight</b>	276 g (9.73 oz)	

## Mechanical Specifications

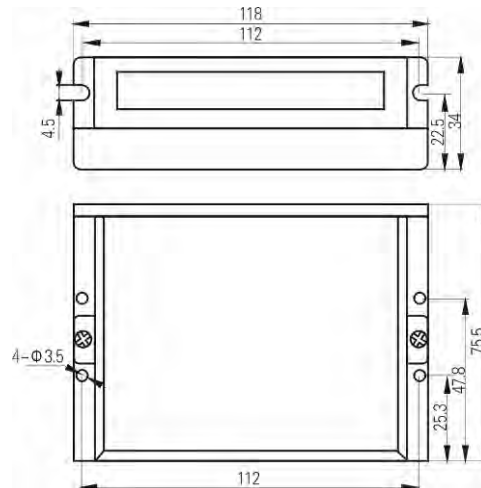



## Protection Indications

The green indicator turns on when power-up. When drive protection is activated, the red LED blinks periodically to indicate the error type

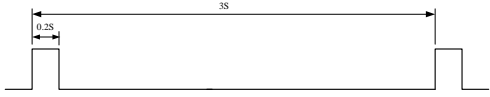
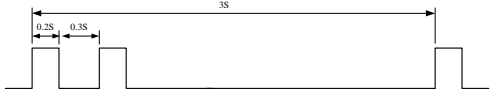
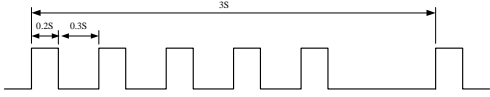
Priority	Time(s) of Blink	Sequence wave of RED LED	Description
1st	1		Over-current protection
2nd	2		Over-voltage protection
3rd	5		Motor Stall Protection

## Connectors and Pin Assignment

The EM705 has two connectors, connector for control signals connections, and connector for power and motor connections.

Control Signal Connector			
Pin	Name	I/O	Description
1	PUL+	I	<u>Pulse signal</u> : In single pulse (pulse/direction) mode, this input represents pulse signal, each rising or falling edge active (software configurable, see EM drives software operational manual for more detail); In double pulse mode (software configurable), this input represents clockwise (CW) pulse, active both at high level and low level. 4-5V when PUL-HIGH, 0-0.5V when PUL-LOW. For reliable response, pulse width should be longer than 10 $\mu$ s. Series connect resistors for current-limiting when +12V or +24V used. The same as DIR and ENA signal.
2	PUL-	I	
3	DIR+	I	<u>Direction Signal</u> : In single-pulse mode, this signal has low/high voltage levels, representing two directions of motor rotation. In double-pulse mode (software configurable), this signal is counter-clock (CCW) pulse, active both at high level and low level. For reliable motion response, DIR signal should be ahead of PUL signal by 5 $\mu$ s at least. 4-5V when DIR-HIGH, 0-0.5V when DIR-LOW. Please note that rotation direction is also related to motor-driver wiring match. Exchanging the connection of two wires for a coil to the driver will reverse motion direction. The direction signal's polarity is software configurable.
4	DIR-	I	
5	ENA+	I	<u>Enable signal</u> : This signal is used for enabling/disabling the driver. In default, high level (NPN control signal) for enabling the driver and low level for disabling the driver. Usually left <b>UNCONNECTED (ENABLED)</b> . Please note that PNP and Differential control signals are on the contrary, namely Low level for enabling. The active level of ENA signal is software configurable.
6	ENA-	I	
7	FLT+	O	<u>Fault Signal</u> : OC output signal, active when one of the following protection is activated: over-voltage, over current, short circuit and stall-error. This port can sink or source 20mA current at 24V. In default, the resistance between FLT+ and FLT- is low impedance in normal operation and become high when EM705 goes into error. The active level of fault signal is software configurable. See EM drives software operational manual for more detail.
8	FLT-	O	

Power and Motor Connector			
Pin	Name	I/O	Description
1	A+	O	Motor Phase A+
2	A-	O	Motor Phase A-
3	B+	O	Motor Phase B+
4	B-	O	Motor Phase B-
5	+Vdc	I	Power Supply Input (Positive), 24-63VDC recommended, leaving rooms for voltage fluctuation and back-EMF.
6	GND	GND	Power Ground (Negative)

### RS232 Communication Port

It is used to configure the peak current, microstep, active level, current loop parameters and anti-resonance parameters. See EM driver's software operational manual for more information.

RS232 Communication Port			
Pin	Name	I/O	Description
1	NC	-	Not connected.
2	+5V	O	+5V power only for STU (Simple Tuning Unit).
3	TxD	O	RS232 transmit.
4	GND	GND	Ground.
5	RxD	I	RS232 receive.
6	NC	-	Not connected.

### DIP Switch Settings

#### Dynamic Current

Peak	RMS	SW1	SW2	SW3
Default	Default	on	on	on
1.4A	1.0A	of	on	on
2.3A	1.6A	on	off	on
3.2A	2.3A	off	off	on
4.2A	3.0A	on	on	off
5.1A	3.6A	of	on	off
6.0A	4.3A	on	off	off
7.0A	5.0A	off	off	off

**Note:** Due to motor inductance, the actual current in the coil may be smaller than the dynamic current setting, particularly under high speed condition.

### Idle-Current

SW3 determines whether the idle current is reduced automatic or remains the same as the dynamic current setting.

	ON	OFF
<b>SW4</b>	The motor idle current reduces automatically when there is no pulse applied to EM705.	The motor idle current is the same as the dynamic current when there is no pulse applied to EM705.

### Auto-Configuration

Switch SW4 two times in two seconds to auto-configure the drive's current loop parameter. That is, OFF-ON-OFF or ON-OFF-ON. During Auto-configuration, motor parameters are identified and the EM drive's current loop parameters are calculated automatically. The motor shaft will vibrate a little during the process of Auto-configuration which takes about 1 to 3 seconds.

### Microstep Resolution

Steps/Revolution	SW5	SW6	SW7	SW8
<b>Software Configured (Default 200)</b>	on	on	on	on
<b>400</b>	off	on	on	on
<b>800</b>	on	off	on	on
<b>1600</b>	off	off	on	on
<b>3200</b>	on	on	off	on
<b>6400</b>	off	on	off	on
<b>12800</b>	on	off	off	on
<b>25600</b>	off	off	off	on
<b>1000</b>	on	on	on	off
<b>2000</b>	off	on	on	off
<b>4000</b>	on	off	on	off
<b>5000</b>	off	off	on	off
<b>8000</b>	on	on	off	off
<b>10000</b>	off	on	off	off
<b>20000</b>	on	off	off	off
<b>25000</b>	off	off	off	off

**Motor Selection and Pre-matching Leadshine Motor**

There is a rotation switch used for the motor selection.

Matching Motor	Connection	Code	Description
57HS09	Parallel	0	Select pre-matching Leadshine stepper motor. EM705 has been tuned for these motors.
57HS13	Parallel	1	
57HS22	Parallel	2	
86HS35	Parallel	3	
86HS45	Parallel -	4	
86HS85	Parallel	5	
57HS09	Series	6	
57HS13	Series	7	
57HS22	Series	8	
86HS35	Series	9	
86HS45	Series	A	Select non-Leadshine motor. EM705 needs tuning either by Auto-configuration or the PC software. There are up to four custom positions for customer selection.
86HS85	Series	B	
Custom1	-	C	
Custom2	-	D	
Custom3	-	E	
Custom4	-	F	

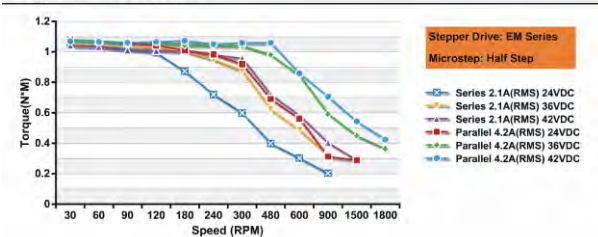
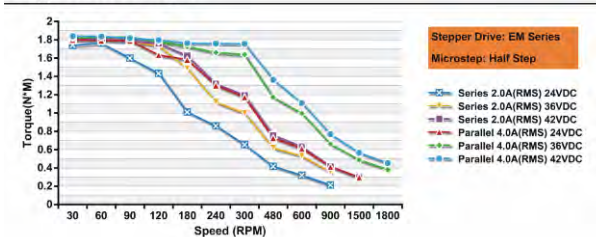
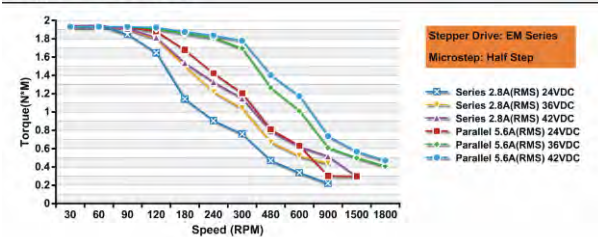
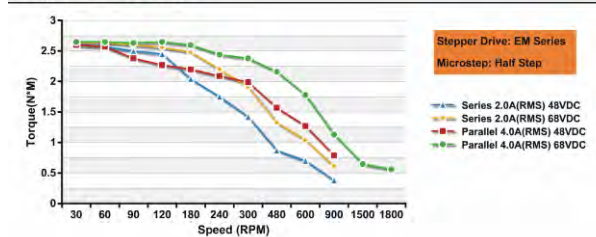
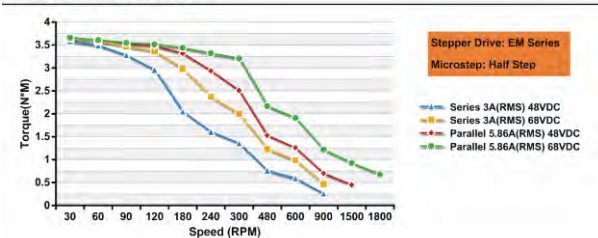
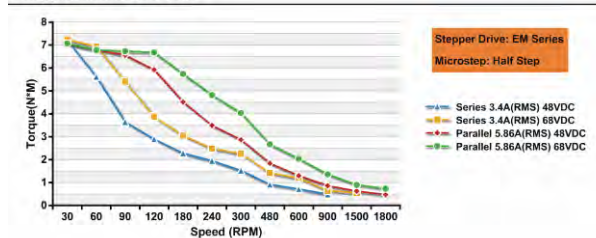
**Speed Torque Curve for Pre-matching Leadshine Motor**
**Stepper Motor: 57HS09**

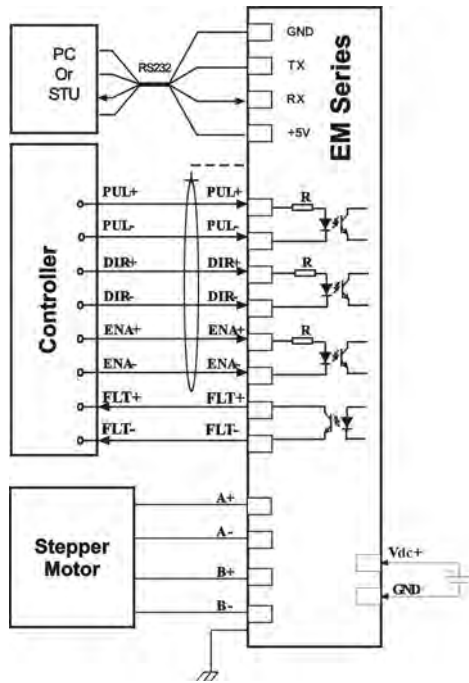
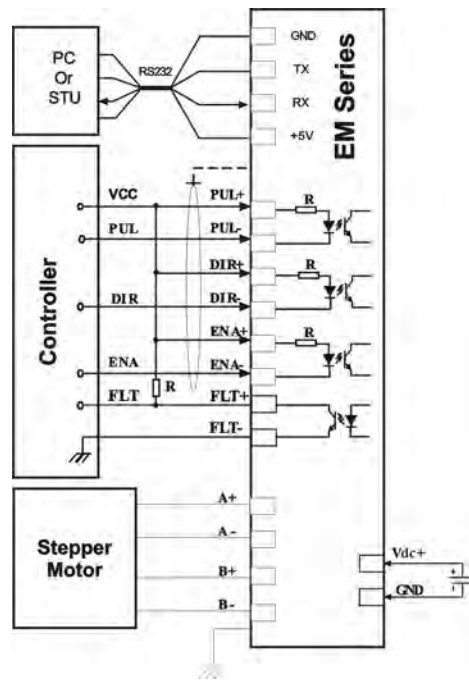
**Stepper Motor: 57HS13**

**Stepper Motor: 57HS22**

**Stepper Motor: 86HS35**

**Stepper Motor: 86HS45**

**Stepper Motor: 86HS85**

**Typical Connections**
**Differential Control Signal**

**NPN Control Signal**



# EM806 2-phase Digital Stepper Drive

## 24-80V, 0.35-6A, Sensorless Stall Detection, Pre-Matching Motor

- n **Sensorless stall detection** eliminates cost of feedback devices and time of cable connection
- n **Super-low** motor noise offers excellent quietness
- n **User password protection** prevents others from copying your drive configurations
- n **Anti-Resonance** optimizes torque and nulls mid-range instability
- n Self-test and Auto-configuration technology offers optimum performance for different motors
- n Multi-stepping allows a low resolution input to produce a higher microstep output for smoother system performance
- n Options to set output current and microstep resolutions via DIP switch or software
- n Command input of PUL/DIR or CW/CCW, Microstep from 1 to 512
- n Automatic idle-current reduction and reduction rate is software configurable
- n Over-current, over-voltage, short-circuit protections besides sensorless stall detection
- n Fault out prevents damages to your machines or the materials



### Descriptions

By implementing the latest motion control technologies, Leadshine's EM series DSP-based stepper drives deliver excellent performance not available before. Unique features of sensorless stall detection, extra smoothness and excellent high speed performance make EM stepper drives deliver servo-like performance at the cost of stepper drives. They are capable of delivering high performance without damages to your machines or the materials. Leadshine EM series stepper drives are able to drive 2-phase or 3-phase stepper motors from NEMA8 to NEMA42.

### Applications

EM806 stepper drives are suitable for driving a wide range of 2-phase stepper motors, from NEMA frame size 23 to 42. Typical applications include CNC routers, laser cutters, laser markers, medical equipments, X-Y tables, measurement equipments, etc.

**Specifications**

**Electrical Specifications**

Parameter	Min	Typical	Max	Unit
Input Voltage	24	68	80	VDC
Pulse Input Frequency	0	-	200	kHz
Logic Signal Current	7	10	16	mA
Isolation Resistance	500	-	-	MΩ

**Operating Environment**

<b>Cooling</b>	Natural Cooling or Forced cooling	
<b>Operating Environment</b>	Environment	Avoid dust, oil fog and corrosive gases
	Storage Temperature	-20°C — 65°C (-4°F — 149°F)
	Ambient Temperature	0°C — 50°C (32°F — 122°F)
	Humidity	40%RH — 90%RH
	Operating Temperature (Heat Sink)	70°C (158°F) Max
	Vibration	10-55Hz, 0.15mm/s
<b>Storage Temperature</b>	-20°C — 65°C (-4°F — 149°F)	
<b>Weight</b>	560g (19.75oz)	

**Mechanical Specifications**

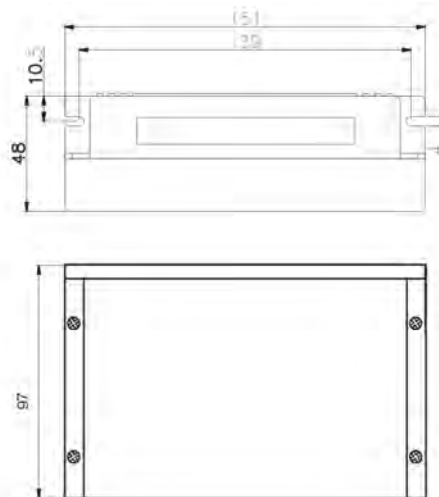

**Protection Indications**

The green indicator turns on when power-up. When drive protection is activated, the red LED blinks periodicity to indicate the error type

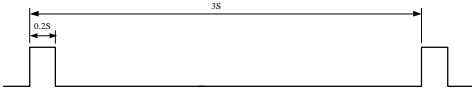
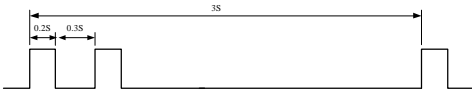
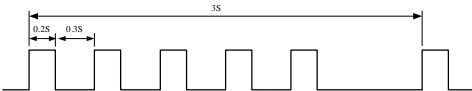
Priority	Time(s) of Blink	Sequence wave of RED LED	Description
1st	1		Over-current protection
2nd	2		Over-voltage protection
3rd	5		Motor Stall Protection

**Connectors and Pin Assignment**

The EM806 has two connectors, connector for control signals connections, and connector for power and motor connections.

Control Signal Connector			
Pin	Name	I/O	Description
1	PUL+	I	<u>Pulse signal</u> : In single pulse (pulse/direction) mode, this input represents pulse signal, each rising or falling edge active (software configurable, see EM drives software operational manual for more detail); In double pulse mode (software configurable), this input represents clockwise (CW) pulse, active both at high level and low level. 4-5V when PUL-HIGH, 0-0.5V when PUL-LOW. For reliable response, pulse width should be longer than 10µs. Series connect resistors for current-limiting when +12V or +24V used. The same as DIR and ENA signal.
2	PUL-	I	
3	DIR+	I	<u>Direction Signal</u> : In single-pulse mode, this signal has low/high voltage levels, representing two directions of motor rotation. In double-pulse mode (software configurable), this signal is counter-clock (CCW) pulse, active both at high level and low level. For reliable motion response, DIR signal should be ahead of PUL signal by 5µs at least. 4-5V when DIR-HIGH, 0-0.5V when DIR-LOW. Please note that rotation direction is also related to motor-driver wiring match. Exchanging the connection of two wires for a coil to the driver will reverse motion direction. The direction signal's polarity is software configurable.
4	DIR-	I	
5	ENA+	I	<u>Enable signal</u> : This signal is used for enabling/disabling the driver. In default, high level (NPN control signal) for enabling the driver and low level for disabling the driver. Usually left <b>UNCONNECTED (ENABLED)</b> . Please note that PNP and Differential control signals are on the contrary, namely Low level for enabling. The active level of ENA signal is software configurable.
6	ENA-	I	
7	FLT+	O	<u>Fault Signal</u> : OC output signal, active when one of the following protection is activated: over-voltage, over current, short circuit and stall-error. This port can sink or source 20mA current at 24V. In default, the resistance between FLT+ and FLT- is low impedance in normal operation and become high when EM806 goes into error. The active level of fault signal is software configurable. See EM drives software operational manual for more detail.
8	FLT-	O	

Power and Motor Connector			
Pin	Name	I/O	Description
1	A+	O	Motor Phase A+
2	A-	O	Motor Phase A-
3	B+	O	Motor Phase B+
4	B-	O	Motor Phase B-
5	+Vdc	I	Power Supply Input (Positive), 24-72VDC recommended, leaving rooms for voltage fluctuation and back-EMF.
6	GND	GND	Power Ground (Negative)

### RS232 Communication Port

It is used to configure the peak current, microstep, active level, current loop parameters and anti-resonance parameters. See EM driver's software operational manual for more information.

RS232 Communication Port			
Pin	Name	I/O	Description
1	NC	-	Not connected.
2	+5V	O	+5V power only for STU (Simple Tuning Unit).
3	TxD	O	RS232 transmit.
4	GND	GND	Ground.
5	RxD	I	RS232 receive.
6	NC	-	Not connected.

### DIP Switch Settings

#### Dynamic Current

Peak	RMS	SW1	SW2	SW3
Default	Default	on	on	on
2.7A	1.93A	of	on	on
3.6A	2.57A	on	off	on
4.6A	3.29A	off	off	on
5.5A	3.93A	on	on	off
6.4A	4.57A	of	on	off
7.3A	5.21A	on	off	off
8.2A	5.86A	off	off	off

**Note:** Due to motor inductance, the actual current in the coil may be smaller than the dynamic current setting, particularly under high speed condition.

### Idle-Current

SW3 determines whether the idle current is reduced automatic or remains the same as the dynamic current setting.

	ON	OFF
SW4	The motor idle current reduces automatically when there is no pulse applied to EM806.	The motor idle current is the same as the dynamic current when there is no pulse applied to EM806.

### Auto-Configuration

Switch SW4 two times in two seconds to auto-configure the drive's current loop parameter. That is, OFF-ON-OFF or ON-OFF-ON. During Auto-configuration, motor parameters are identified and the EM drive's current loop parameters are calculated automatically. The motor shaft will vibrate a little during the process of Auto-configuration which takes about 1 to 3 seconds.

### Motor Selection and Pre-matching Leadshine Motor

There is a rotation switch used for the motor selection.

Matching Motor	Connection	Code	Description	
57HS09	Parallel	0	Select pre-matching Leadshine stepper motor. EM806 has been tuned for these motors.	
57HS13	Parallel	1		
57HS22	Parallel	2		
86HS35	Parallel	3		
86HS45	Parallel -	4		
86HS85	Parallel	5		
57HS09	Series	6		
57HS13	Series	7		
57HS22	Series	8		
86HS35	Series	9		
86HS45	Series	A		
86HS85	Series	B		
Custom1	-	C		Select non-Leadshine motor. EM806 needs tuning either by Auto-configuration or the PC software. There are up to four custom positions for customer selection.
Custom2	-	D		
Custom3	-	E		
Custom4	-	F		

### Pulse Active Edge

	ON	OFF
SW8	Active rising edge of pulse.	Active falling edge of pulse

**Microstep Resolution**

Steps/Revolution	SW5	SW6	SW7
Software Configured (Default 200)	on	on	on
400	off	on	on
800	on	off	on
1600	off	off	on
3200	on	on	off
6400	off	on	off
12800	on	off	off
25600	off	off	off

**Speed Torque Curve for Pre-matching Leadshine Motor**

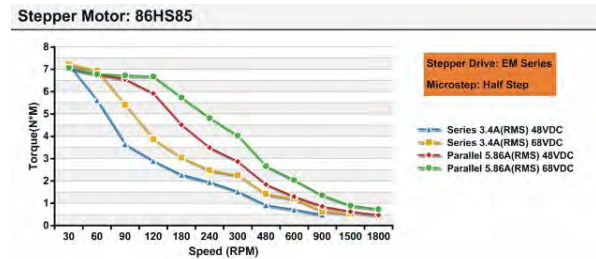
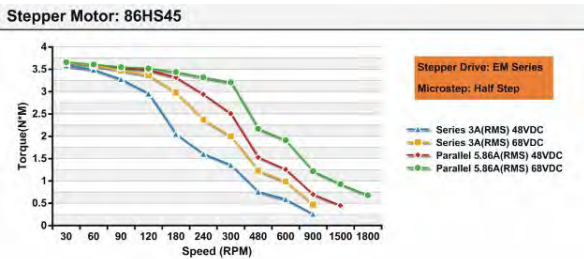
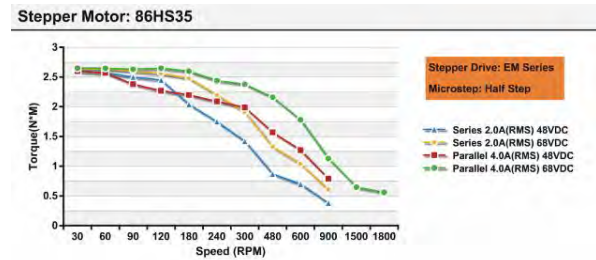
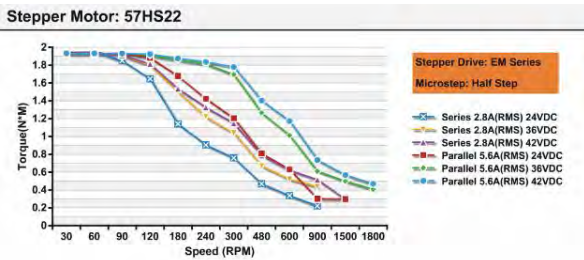
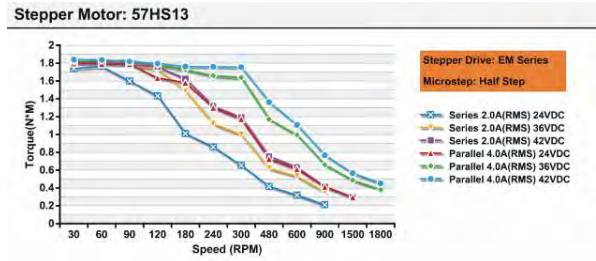
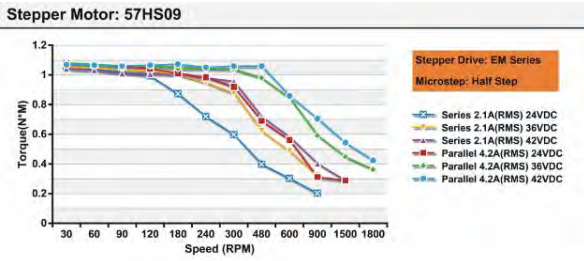



**Typical Connections**

**Differential Control Signal**

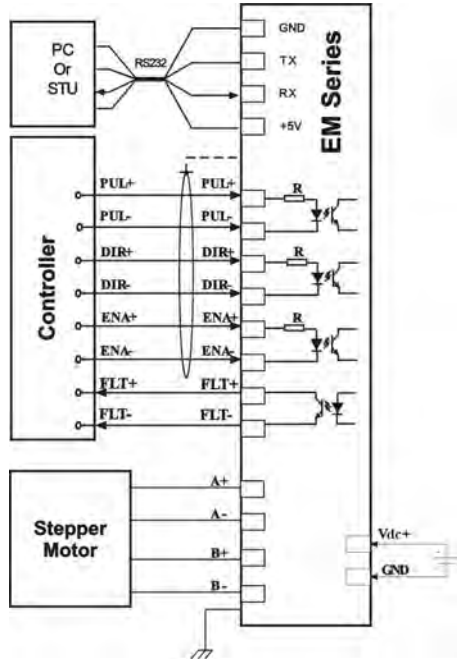

**NPN Control Signal**

